

# OEM Friendly Profiles



## Arquati Company USA

**Name:** Victorian Black

**Number:** 350105A

**Material:** wood

**Finish:** Gesso finish with a black surface coating, red highlights on the ornamentation, and a gray patina wash in the recessed areas.

**Size:** height: 1 7/8" width: 2 3/4"

**Suggested Use:** Small Dutch oils, larger traditional, Latin images, and antique engravings and prints.

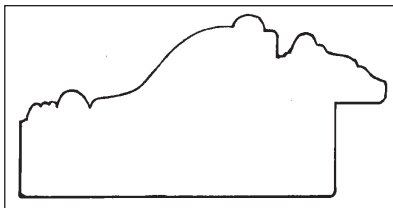

## Designer Moulding - Wood Division

**Name:** Traditions

**Number:** 414905

**Material:** wood

**Finish:** Black with gold beaded lip.

**Size:** height: 2" width: 4"

**Suggested Use:** Ideal for oil paintings, Old Masters, formal framing, and mirrors.

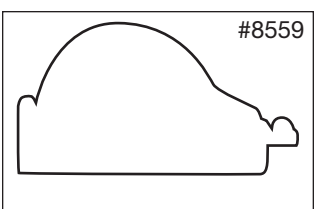
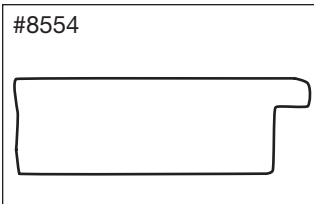

## Wall Moulding

**Number:** 8559; 8554

**Material:** wood

**Finish:** Dark, distressed gold.

**Size:** 8559: height: 2" width: 3 7/8"  
8554: height: 3/4" width: 2 1/2"

**Suggested Use:** diverse projects



## Studio Moulding

**Name:** B&B

**Number:** 1420, 2520, 1620

**Material:** wood

**Finish:** Dark Sable Brown Natural Grain Finishes

**Size:** 8 profiles + fillet  
from 7/8"w x 1 1/8"h to 3"w x 1 1/16"h

**Suggested Use:** Photos, hotels, hospitals, diverse projects

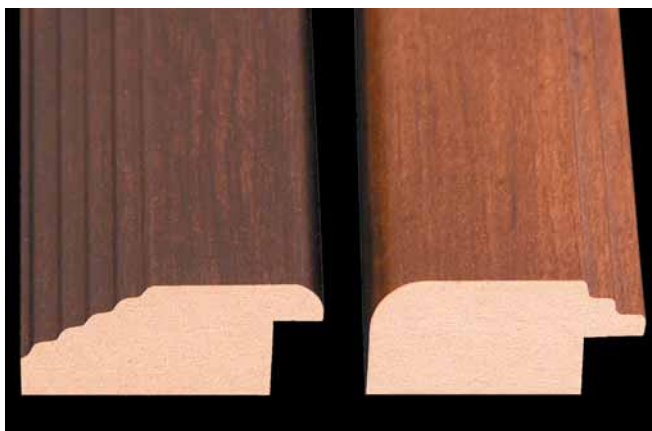

### Framerica

**Name:** BonanzaWood™ “Stair” from the Woods Collection

**Number:** 14000; 31000

**Material:** BonanzaWood™

**Finish:** Available in more than 20 finishes, including Mocha (medium brown) and Espresso (dark brown).

**Size:** 14000: height: 3/4" width: 1 3/8"  
31000: height: 3/4" width: 1 1/2"

**Suggested Use:** The step-like design on the rabbet and flat top provides a unique look for all types of artwork.

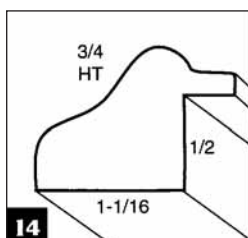
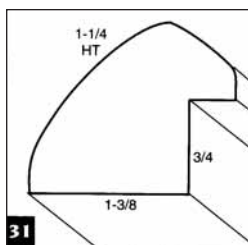

### Max Moulding

**Name:** Regent Metallics Collection

**Number:** S931 Series; S930 Series; S933 Series

**Material:** wood

**Finish:** Gold and Silver leaf finishes in Satin Steel Gray, Satin Pewter, Satin Copper, and Satin Brass.

**Size:** S931 height: 1 3/4" cap width: 1 5/8"  
S930 height: 2 3/8" cap width: 2 5/8"  
S933 height: 1 3/4" floater width: 2"

**Suggested Use:** Floaters are ideal for canvas oil paintings. Popular profiles with contemporary palette of metallic finishes are suitable for photography, abstract art, and modern art. Caps are stackable mouldings and used for collages and 3-D art.

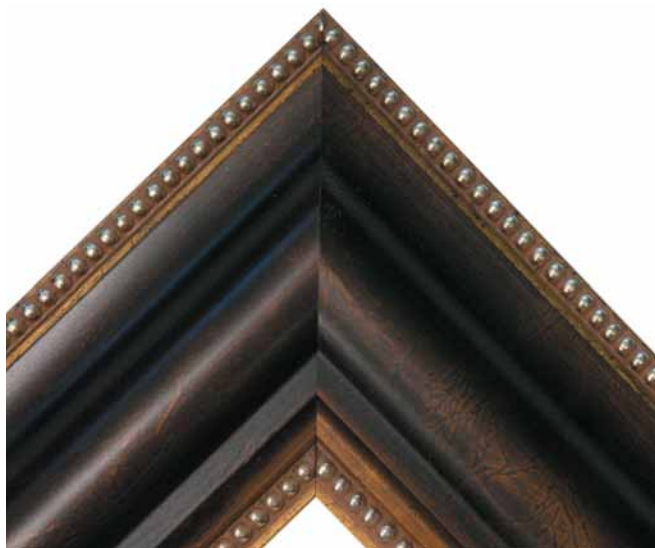

### Universal Framing Products

**Name:** Bellagio Collection

**Number:** NC500

**Material:** wood

**Finish:** Bronze/gold leaf acid wash with bead ornamentation.

**Size:** height: 1 5/8"  
width: 3 1/2"

**Suggested Use:** Traditional wildlife to Neoclassical architecture and antiques.

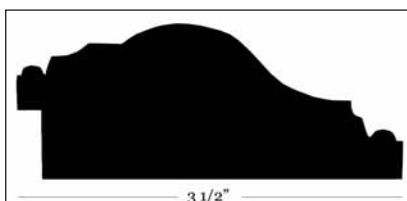

### The Sloane Collection Omega Moulding

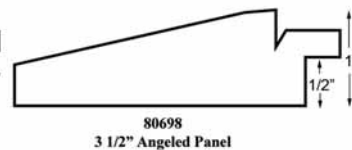
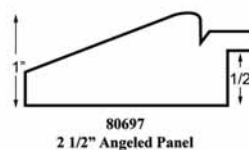
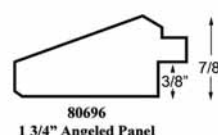
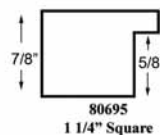

### Omega Moulding

**Name:** Sloane Collection

**Number:**

**Material:** wood

**Finish:** Flat matte black with textured brush finish.

**Size:** height: 2" width: 4"

**Suggested Use:** Ideal for black-and-white or color photography, traditional or contemporary artwork, and in interiors from classic traditional to eclectic modern.



**T.I. Industries**

**Name:** Newport  
**Number:** 065-041  
**Material:** Plantation Pine™  
**Finish:** Vintage Espresso tone with worn antique finish.  
**Size:** height: 1 1/4" width: 4"  
**Suggested Use:** For all applications, especially vintage posters, botanicals, landscapes, wildlife, and contemporary pieces.

**Nurre Caxton**

**Name:** Metropolitan Floaters  
**Number:** 725; 731; 732  
**Material:** wood  
**Finish:** Antique Silver, Antique Gold, Antique Black, and four natural wood finishes  
**Size:** 725: height: 1 3/8" width: 1"  
 731: height: 1 3/4" width: 2"  
 732: height: 2" width: 2 7/16"  
**Suggested Use:** Framing canvas.

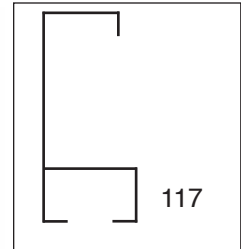
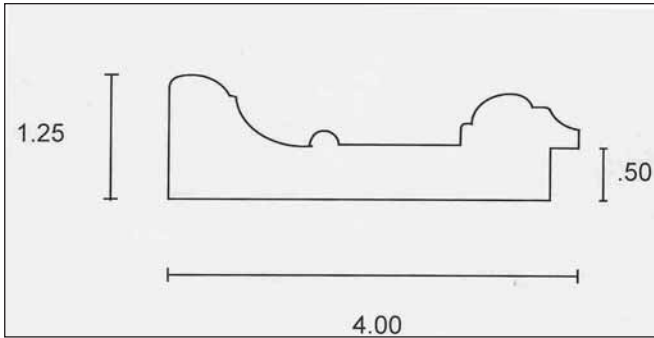
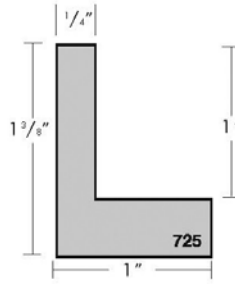

**Nielsen**

**Name:** Profile 117  
**Number:** 414905  
**Material:** metal  
**Finish:** Vivids specialty finish  
**Size:** height: 1 5/16" width: 7/16"  
 rabbet depth: 3/16"  
**Suggested Use:** Designed for photography and more contemporary treatments.

**ProductionLiner**

— built to order, just in time.

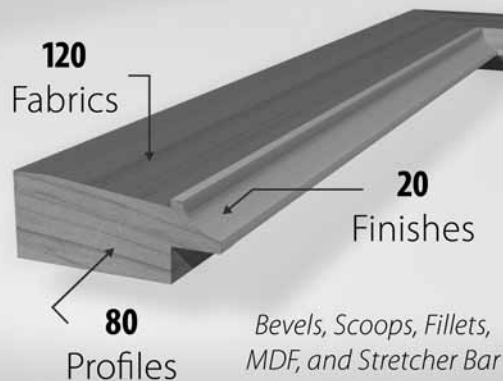

[www.LinenLiners.com/Products](http://www.LinenLiners.com/Products)

Express Design Samples · Same Day Quotes  
 Short Lead Times · Import Prices

*Linen Liners, Inc.*

a division of GLC General, Inc.

**1-800-742-2876**

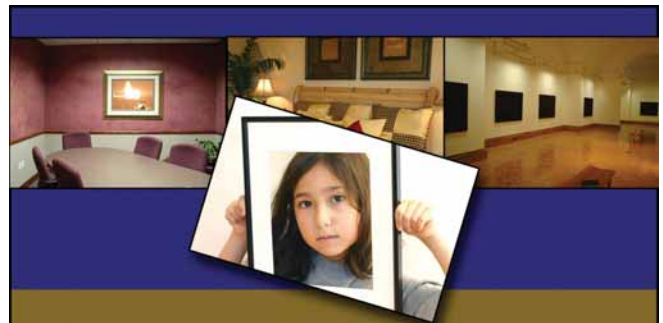

**TrackMaster® Picture Hangers for Every Application**

- Solves the Crooked "Hook and Wire" Problem
- Stable and Self-Leveling
- Wood and Metal Frames
- Attach to Any Wall Surface
- Security Options Available
- Integrated Bubble Level



**OEMs and Distributors Call Now to Learn More about this High Profit Product:**

**(866) 792-8675**

Resellers order online: [www.HangFrames.com](http://www.HangFrames.com)  
 or call Pinon Marketing Group, Inc., (888) 776-2531  
 (Generous Discounts for Qualified Resellers)

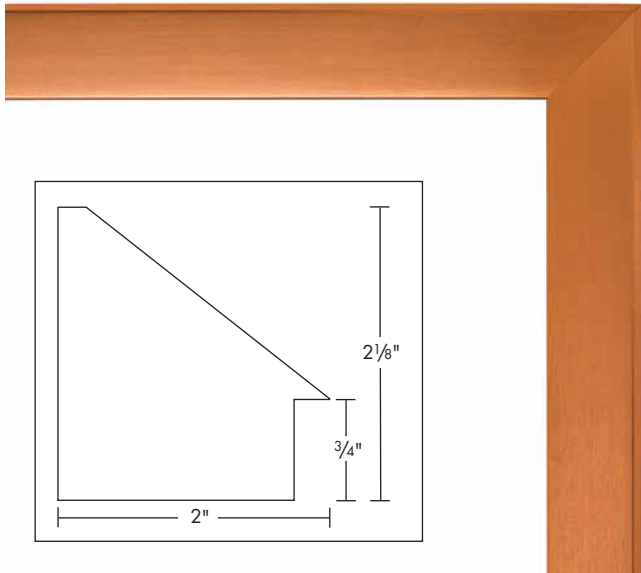

**Michelangelo Moulding**

**Name:** Avant-Garde Collection

**Number:** 198-32

**Material:** wood

**Finish:** Copper finish

**Size:** height: 2 1/8" width: 2" and 1 1/2"

**Suggested Use:** Contemporary prints with copper colors and accents.



**Howell Mouldings**

**Name:** Antique Gold

**Number:** LD-1

**Material:** polystyrene

**Finish:** Foiled gold.

**Size:** height: 3/4" width: 1"

**Suggested Use:** Elegant art.

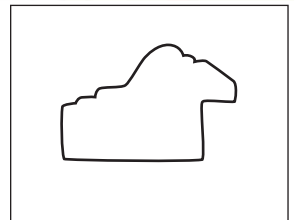

# You don't have to *be* a big dog to *run* with them.



You already know that SpecialtySoft® is the leading business management software for smaller frame shops who want to grow. But did you know that a version of our product also serves the multi-site frame shops? And that another version provides business and production management for OEM framers?



CALL US TODAY FOR A **FREE** DEMO & VIDEO TUTORIAL: 1-800-417-9248 | sales@specialtysoft.com