

# FEATURE PRODUCTS

**E**quipment, supplies,  
and moulding  
specifically for the production  
framing market.



### Wall Moulding & Associates

The polystyrene moulding line has been expanded to include more than 25 new mouldings this year. Samples upon request.

**Call: 800-880-9315**

**www.wallmoulding.com**



### Bienfang

Roller Press offers a fast, easy way to mount and laminate. It has adjustable roller speed and thickness settings and the 42" roller length provides the capability of processing multiple pieces at once. Its high-quality silicone rollers promote easy clean up. Made in the U.S., it comes with a lifetime of technical support.

**Call: 888-240-6021**

**www.forframersonly**



### Gunnar

Offering two models of Swiss-engineered computerized mat cutters designed for high volume picture frames or OEM manufacturers. Choose from either the Gunnar 601-XL or the Gunnar 3001-M or XL. Both Industrial Line models offer numerous features and designs that maximize productivity and provide cost savings through improved material yield.

**Call: 877-722-7856**

**www.gunnar-international.com**



### Pistorius

The new, automated Material Push Feeder is shown here, installed on a double mitre saw. It features automatic ejection of the finished piece and conveyorized return of the part to the operator for secondary operations, including packing and joining. It is designed for same length materials such as pre-cut wood mouldings, PVC, MDF, or aluminum extrusions. The software has provisions for initial trim off and makes allowances for scrap between saw-blades. This system offers fast loading and programming capabilities. Operators can load and unload simultaneously.

**Call: 631-582-6000**

**www.pistorius.com**



### The Fletcher-Terry Company

The Future Plus computerized mat cutter now offers an even faster cutting speed of more than 31" per second. "Cut from the front" operating efficiency produces precise curves and cut quality from the thinnest foil to the densest 8-ply board. Designed for high-speed cutting around the clock, the Future GTO takes on large production jobs with the ability to cut 46" per second. The GTO can be run by either one or two operators.

**Call: 800-843-3826**  
**www.fletcher-terry.com**

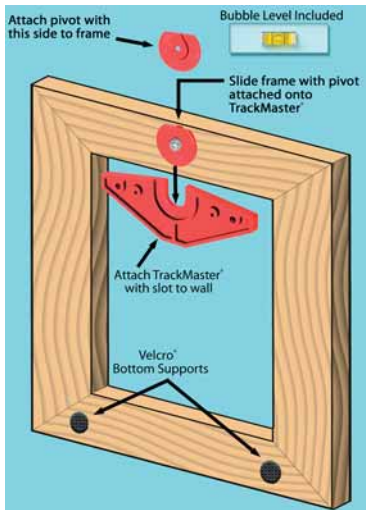

### Trackmaster®, Inc.

The new Pivot Hanger was designed primarily to eliminate the labor costs of pre-installing hooks and wires. It improves frame security and comes in an all-in-one package with its own level.

**Call: 505-792-8675**  
**www.hangframes.com**



### Hartman Plastics

New Acid-Free Foamboard is white and smooth and the polystyrene center does not contain acidic materials. Providing years of protection against deterioration, it is pH neutral and essentially lignin free. It comes in standard and custom sizes ranging from 3/16" to 1/8" thick.

**Call: 610-273-7113**  
**www.hartboard.com**



### Framerica

Best described by the "steps" featured on its back, the 31,000 is the latest profile. Its flat face and descending steps provide a timeless, classical look that fits with any type of artwork. The exclusive, 1 1/2" inch wide design is available in 10 finishes, including Black, Walnut, Mahogany, Mocha, and Espresso.

**Call: 800-372-6422**  
**www.framerica.com**



### Ultramitre

Tune-up Preventive Maintenance of major brands of picture framing equipment is now available. The new features allow for an extended equipment life, as well as increased reliability and improvement in product quality. Ultramitre Preventive Maintenance for production equipment is available in and around: Atlanta, Baltimore, Boston, Chicago, Cincinnati, Cleveland, Columbus, Dallas, Denver, Detroit, Greensboro, NC, Houston, Huntsville, Kansas City, Long Island, Los Angeles, Miami, Minneapolis, Orlando, Philadelphia, Phoenix, San Francisco, Seattle, St Louis, and The Tri-state area.

**Call: 800-433-3140**  
**www.ultramitre.com**

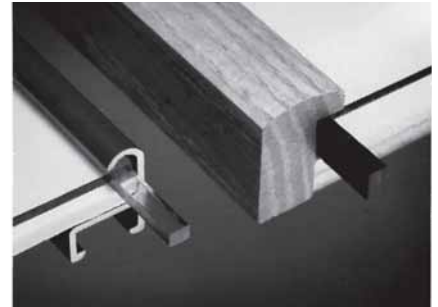

### Arlo

Introducing the solid plastic and acid free Spacemaker Picture Frame Spacers. The spacers create a protective air-space between art and glazing. These quality spacers can be used with wood or metal frames, which helps prevent mildew and other contact damage. They come in Clear, Smoke, or Black with 1/8" and 1/4" thicknesses. Free samples upon request.

**Call: 800-332-2756**

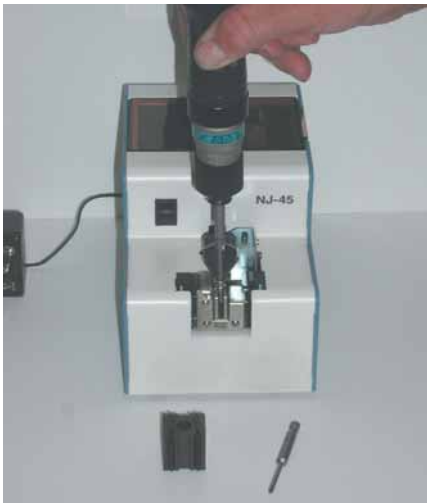

**Art Materials Services, Inc. (AMS)**  
 Introducing the Screw Sorter, the first step in adding automation to the assembly process. The sorter's technology eliminates the need for manual handling of fasteners and shavings, keeping workspace clear. It is compatible with #0 through #10 screws, and can feed speed up to two screws per second. The quick feed rate allows it to switch rails within minutes for different screw sizes. The oscillating hopper design also enables it to hold about 1,000 to 1,500 fasteners, freeing the operator's hands for other use. Requires magnetized bits or a vacuum system.  
**Call: 888-522-5526**  
**www.ArtMaterialsService.com**



**Arakawa Hanging Systems**  
 For more than 20 years, offering integrated multiple rail designs with various quick release cable. Grippers have an award-winning design and come in assorted size and weight options. The new C20 art hook provides adjustability and quality. The C20 hook can be integrated into existing product lines or offered as part of a retail package.  
**Call: 888-ARAKAWA (272-5292)**  
**www.arakawagrip.com**



**Universal Framing Products**  
 The new Double Miter Saw has the ability to cut moulding up to 7" wide and 4" high. This saw is automatic and the package includes two blades with adjustable blade speed, dust collection system, 10 foot right measuring table with sight gauge, four vertical clamps plus production stops, 6½ foot left side table, and an internal work light. The independent blade operation virtually eliminates waste.  
**Call: 800-668-3627**  
**www.universalframing.com**



**Nielsen**  
 Introducing eight new colors in the Vivids series of profiles. These new shades match and complement the latest style trends. Colors include Raspberry Fizz, Tangerine Twist, Copper Peach, Lemon Ice, Emerald, Amethyst, Turquoise, and Gold Bullion. The entire Vivids range is offered on Nielsen profile #117 and provides a minimalist look that is also deep enough to accommodate memorabilia, three-dimensional art and shadowboxing treatments. Now available in a total of 12 colors.  
**Call: 800-526-9073**  
**www.nbframing.com**



**Wizard**  
 Wizard International and Zünd have partnered to present new user-friendly mat design software for CMCs. The MatDesigner software is now capable of powering both the Zünd M800 and M1600 models. Zünd precision cutters are now sold directly to the custom framing industry by Wizard. All Zünd systems purchased from Wizard come complete with the latest version of MatDesigner.  
**Call: 888-855-3335**  
**www.wizardint.com**



**Active Sales Company**  
 The CanvasMaster canvas-stretching machine can gallery-wrap giclées or digital images on canvas, blank artist canvas, oil paintings, laminated paper, stitcheries and more. It also has the capability to quickly adjust for different size images and works on frames ½" to 3" thick. Available in 48" and 60" models, the CanvasMaster can stretch art or canvas in about a minute. A full line of pneumatic staplers and nailers, staples and nails and accessories are also available.  
**Call: 800-937-2255**  
**www.activesalesco.com**

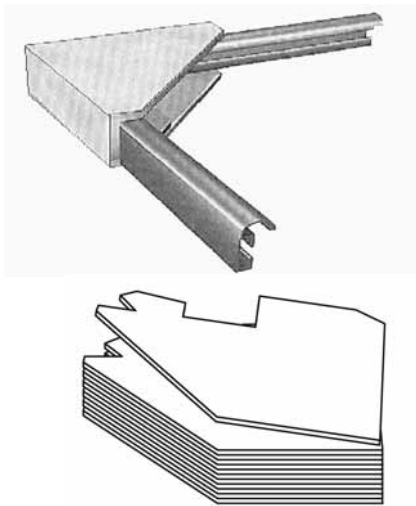

**Impex Industrial Hardware Mfg. Co.**

Corrugated Corners, an exclusive of IIHM, helps cut labor expenses by 70 percent, freight expenses by 15 percent, and allows for workers to fold and insert in half the time. Offered in six styles. Free samples upon request.

**Call: 800-933-0163**  
**www.iihmc.com**



**CTD**

The new Model "Mitre Max" DMC70, Fixed 45 Degree Double Mitre Cross-Cut Saw. Uses an advanced linear track guiding system. This saw will cut mouldings up to 8" wide by 4" high. The cross-cut horizontal action allows the two blades to cross over the fence intersecting point, creating virtually zero scrap. Available in hand operated and pneumatic versions. The machine has 13" blade capacity, two 1.5 H.P. single phase motors, dual magnetic starter, manual horizontal clamps, 48" infeed and outfeed tables, and a 60" long gauge system for measuring inside and outside points.

**Call: 213-689-4455**  
**www.ctdsaw.com**



**SpecialtySoft**

The latest software is an automated frame entry system that allows the user to take a digital image of artwork and display it as framed art for the customer to view. One click automatically measures art and produces a sharp visual representation of frame design. Additional features include multi-opening and the ability to document condition of art on the stored image.

display it as framed art for the customer to view. One click automatically measures art and produces a sharp visual representation of frame design. Additional features include multi-opening and the ability to document condition of art on the stored image.

**Call 800-417-9248**  
**www.specialtysoft.com**



**vnail.com**

Offering V-Nails® and framers points for most machines.

**Call:**  
**888-894-6278**  
**www.vnail.com**



**Frameware**

Introducing an automatic Plastibond glue dispensing system which reduces cost and improves quality, all through precision dispensing. This product is recommended for any high volume production of plastic frames. Operating on air pressure, it allows for a neat, easy clean up process. It dispenses from 1lb. or 4.4 lb. bottles and uses a hand-held applicator for power.

**Call: 800-582-5608**  
**www.framewareinc.com**

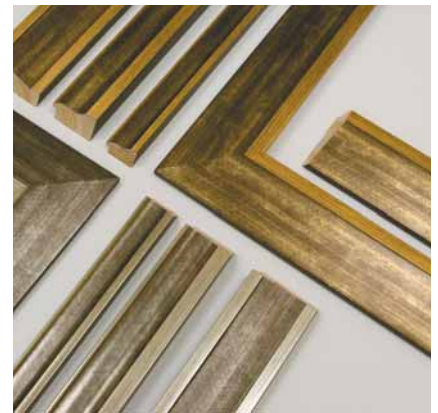

**Omega Moulding**

The Integra line is a modern, sophisticated collection featuring four contemporary profiles in gold and silver finishes enhanced by a dark, crosshatched design on the panels. The wide profiles are suited for contract jobs that require a big wall presence and for custom framing jobs as well. Aggressively priced for the Volume/OEM market. Distribution centers in New York, Memphis, Los Angeles, and Toronto.

**Call: 800-289-6634 (U.S.)**  
**877-452-3799 (Canada)**  
**www.omegamoulding.com**

**ITW AMP**

The Mitre-Mite® Memory Program Multichannel machine is the latest innovation for joining picture frames. The machine provides a very high level of flexibility, incorporating five distinct channels which hold five different V-Nails® (5, 7, 10, 12, 15 mm). The operator has the capability to insert and stack any of these sizes at up to 10 different positions along the frame joint. This facilitates the perfect joining solution especially for wide moulding with variability in height.

**Call: 800-322-4204**  
**www.ITWAMP.com**

